



Pre-installation sheet for BS 510B Band saw.

- 1) The machine would require 2.5 mm² square wire with 4 Core wire 3 phase +, Neutral .and Earthing separately. Length of Wire should be as per the distance of the machine from the main supply.MCB of 10 amp rating required.
- 2) Input supply would be 400V. Proper earthing for the machine is one of the prime necessity, Stabiliser is a must if the Power supply is not proper.
- 3) Raw Material for taking trial and for giving a demo of the machine should be ready.
- 4) Dust collector with 2X100mm hose pipe to be provided. Suction of 1800m³/hr recommended.
- 5) Your kind selves will have to provide one technician and the ONE Operator along with the Service Engineer at the time of installation (one who are going to work and look after the machine once it's installed)
- 6) The installation and training programme would be for 3 days. If due to any cause the above requirements have not been fulfilled and if there is any delay for the installation then the Amt of Rs 5000/ day will be charged as Service Charges and also the Extra days of Engineer lodging and boarding expenses would have to be borne by your kind selves.

7) In Case if the machine is to be shifted from one location to another (From factory go down to location) please arrange for the pallet truck or forklift in advance.

Kindly Sign and Stamp the Pre-installation sheet once you are ready with the installation set up required for your machine and send it to us by email/ courier so that we can plan the Engineer for the installation of the Machine.

Caple Industrial Solutions
and Seal
Service Head

Customer sign

Blade length 3962 mm / Width 6 mm to 30 mm /



Key Capacity

A Max Depth of Cut	335mm
B Throat Width	480mm

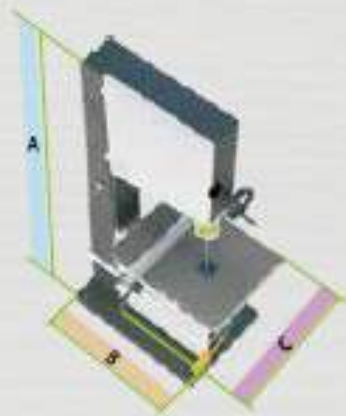

Layout

A	1876mm
B	940mm
C	803mm

Step 1 - Deciding What to Cut

You first need to think about the materials that you will be cutting, you can cut anything with the same saw but might need a different blade. Until you know what you are going to be cutting you won't be able to choose the type of blade which will offer you the best cut and the best features.

Step 2 - Choosing the Blade

Now you know what you are cutting it's time to choose the type of blade. If you're cutting something thin then use a regular band saw blade. This is also useful if you're cutting out intricate details.

If you're cutting anything soft, metals, wood or plastics then a skip tooth blade will work well. These are designed to minimize the chances of the blade snagging and clogging up with swarf.

Any cuts into a thick material such as wood, metal or plastic should use a hook tooth blade. These have angled teeth which make cutting through thick materials much quicker.

Step 3 - Choosing the Tooth Set

When cutting metal using a horizontal band saw a raker tooth set should be used, this is where the teeth are separated so one is pointing to the left, one to the right and one in the centre.

For accurate and quick cutting through wood a straight tooth set or alternate tooth set should be used.

Step 4 - Blade Width

The band saw you have will only be compatible with a certain width of blade. Check through the instructions for your machine and choose a blade which is compatible.

Step 5 - Testing

Whenever you're using a new saw blade it's always a good idea to test cutting using a scrap piece of material. Cut through the scrap off cut to check that you are happy with the finished cut before cutting the actual material.

There are many things which you need to consider when buying band saw blades especially when it comes to setting the teeth. With a bit of experience you should know how to choose the best saw blades to get the best results.

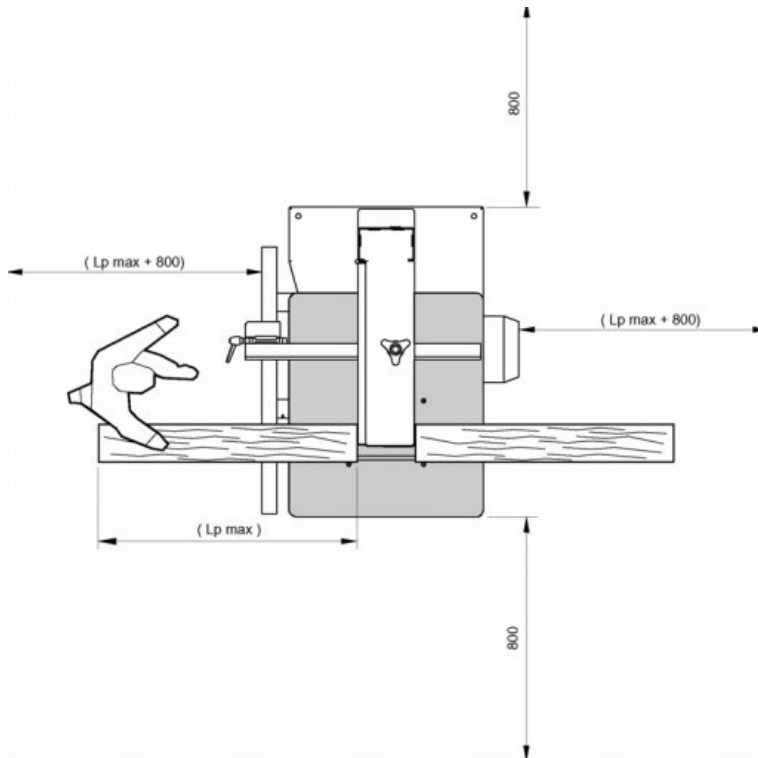

Kindly Arrange to Organise the Following Accessories machines
also for
Band Saw Blade Repair and Grinding.
Grinder



Butt weld machine

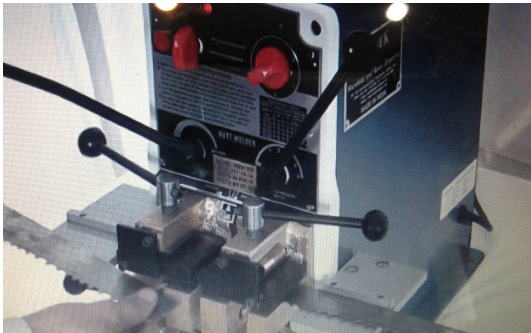

<https://www.youtube.com/watch?v=48ibSP-K2Pk>

TEETH SETTING PLIER

<https://www.youtube.com/watch?v=bR9ImRGBfL4>

