

CNC Machining Center for Cabinet Door NCB2808M

Nanxing Machinery
Guangdong China

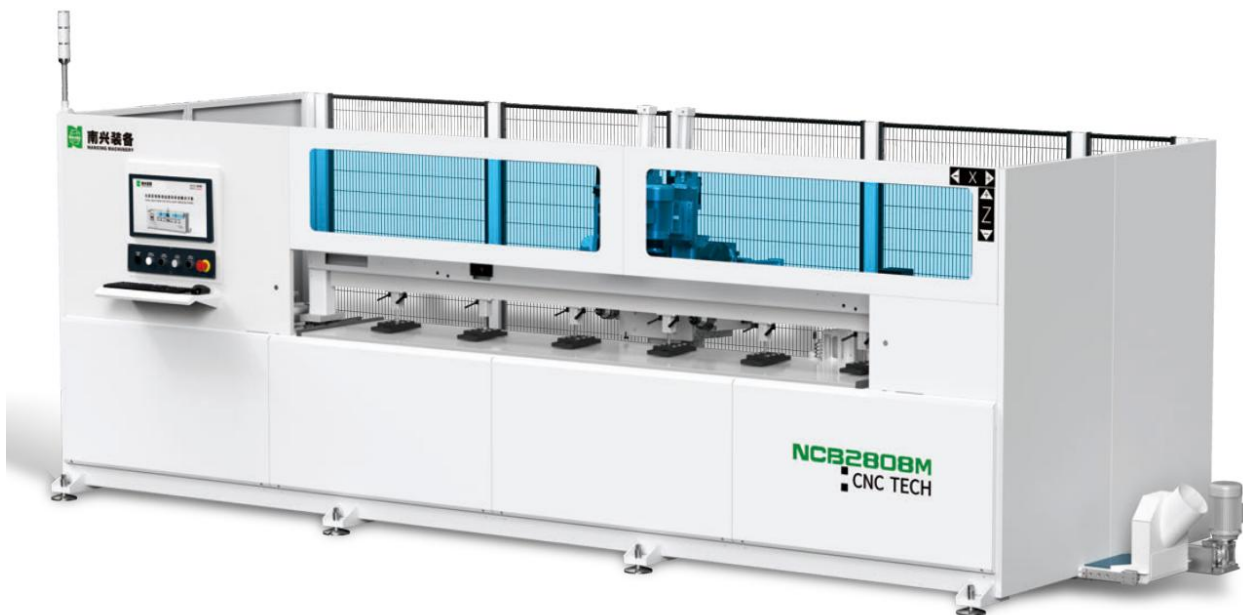

Description

NCB2808M is suitable for processing various door types, such as rocket handles, double handles, straighteners, horn handles and other aluminum alloy handles. It is also suitable for lock holes, hinge holes and side holes. , 45° Lamino (slope motor required) and other process processing.

The processing unit consists of a set of vertical automatic tool-changing spindles and two sets of horizontal spindles, equipped with a 6-position in-line tool magazine and an automatic movable beam.

Specialized operating system, you can customize online 3D drawing editing or retrieve door model library, it can also parse MPR, DXF and other file formats, automatically generate NC, and quickly realize code scanning processing. PC control, flexible software to easy operate.

Details

1. Machine body

- Heavy-duty, high-rigidity structural design, welded, annealed, sanded, and processed in one go to ensure stability during high-speed processing;
- Extended frame, maximum processing length 2800mm.



2. Movement of each axis

X direction

- moved by high-stiffness iDIN6 grade inclined rack and pinion ensure the high precision, stability, smooth running and long service life



Y.Z direction

- Ball screw gives the machine added precision in Y direction. Max speed up to 20m/min;



Servo motors

- Movement of each axis driven by high precise servo motor, 90/20*20m/min.



3. Auto greasing

- Auto grease transmission mechanism automatically, save labour, and ensure the stable and long service life
- Oil pump category: electric grease pump



4. Auto movable beam by cylinder

- Beam moves automatically by cylinder according to different process, so that the workpiece can be pressed tightly coupled with side positioning device.
- Sectional zone pressing, more convenient and efficient, moving range 0-160mm

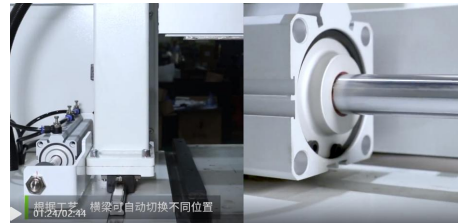

5. Top presser and back positioning bar

- Overwided 6 pcs of top pressers to press boards tightly during processing;.
- Back positioning bar rises automatically

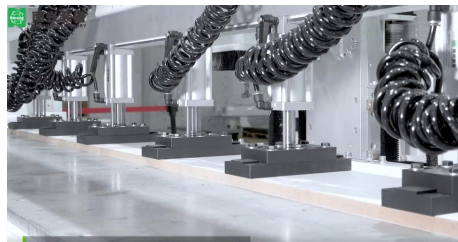

6. 2 Working areas

- 2 working stations to process alternately, reduce waiting time,max processing size 2800*800mm
- High-pressure table plate offers longer service life, wear proof.
- Distance to floor: 980mm, convenient for user to operate and put workpiece.

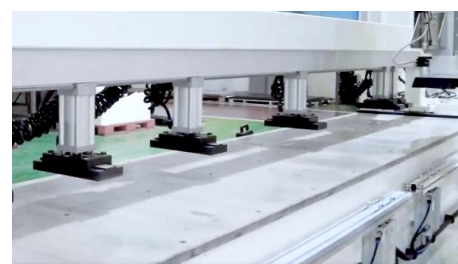

7. Auto board thickness detection

- For accurate processing

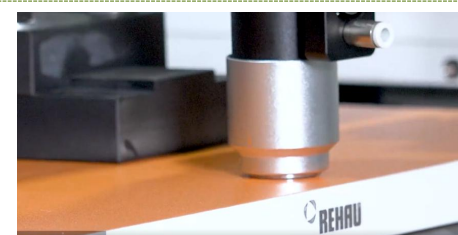



8. Processing unit

- **Vertical spindle 7.5Kw auto tool changer:**
Equipped with 6-tool magazine in a straight row and automatic tool changer. It can process free handles, various embedded handles, parent-child handles, straighteners, light wire ducts, etc.
- **Horizontal milling spindle 6Kw:**
Can process top and bottom hinge holes, door lock holes, etc.
- **Horizontal drilling spindle 3.5Kw:**
Side drilling
- **7.5kw vertical main spindle**
Manually change tool. Can process free handles, various embedded handles, parent-child handles, straighteners, lamp cable ducts, etc.
- **2 pcs 2.2kw bevel direction main spindles:**
One Can process 45 degree bevel Lamello groove.
The other used to drill Lamello hole etc.

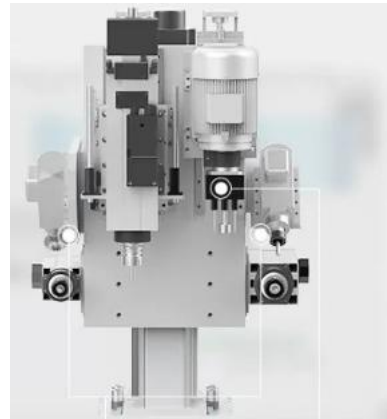
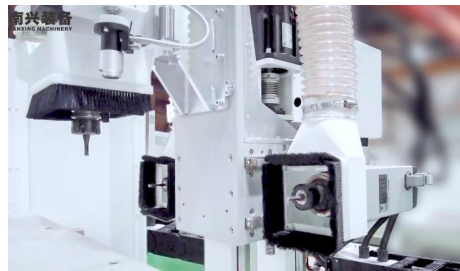

Board size

- Max processing size: 2900*600mm
- Mini processing size: 250*200mm

9. 6-slot Line tool changer

- 6-position line tool magazine , ISO30 tool collect, meet different processing requirements;



10. Cable chain

- High-quality cable chain protects electric wire and air tube during main spindle moving, longer service life;
- It can withstand millions times of bending and movement of the cable



11. Two tool setting gauges

- One gauge in vertical direction, the other one in horizontal direction, Automatic tool setting is precise and fast which ensures machine continuous working without need of changing tool by hand, save time.



12. IPC control

- Powerful, IPC control, window system



13. Intelligent operating system

- Userfriendly, with online 3D graphics editing and simulation;
- It can interconnect with the dismantling software, parse MPR format, and support CSV, BAN, and XML formats, EXCEL file import, DXF file import;

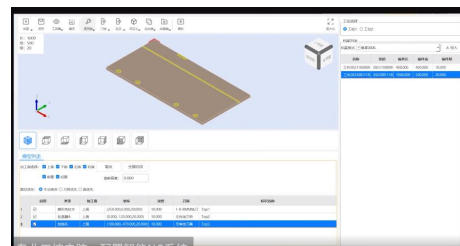

14. Bar code scanner

- Scan bar-code to call relevant processing programs, Information-based production





15. Processing various door types

- Rocket handles, double handles, straighteners, horn handles and other aluminum alloy handles



16. Control cabinet

- Most components are using famous brand for longer service life and stability.
- Clean European wiring, clean and easy for trouble shooting



17. Safety fence

- Machine is standard with safety fence ensures the safety of operators

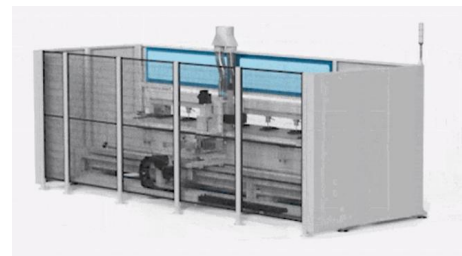



Technical Data

Panel width	200-800mm	
Panel length	250-2800mm	
Panel thickness	10-60mm	
Working range	X axis :250-2800mm Z axis: 60mm	Y axis: 160mm
Travelling speed	X axis: 90m/min Z axis: 20m/min	Y axis: 90m/min
Moving beam range	0-160mm	
Working table	Area: 2,660mmx420mm	Height: 980mm
Main spindle	Qty. 5 Rotating speed: 18000rpm	Power: 7.5kw vertical spindle + 6kw horizontal spindle + 3.5kw horizontal spindle+2*2.2kw bevel spindles
Tool change	Qty.6	Type ISO 30
Drilling depth	60mm	
Power supply	Voltage: 380V, 3-phase	Frequency: 50 Hz
Dust collector	Φ150mm*2	
Total power	33.67kw	
Floor space	L×W×H: 5,820×2,520×2,000 mm	
Net weight	2,200kg	

**Thanks for the attention!*

The company continuous to improve the product specifications and design details, the specifications are subject to change without notice. 241011